



TRUE UNION (DOUBLE UNION) BALL VALVE

本產品榮獲NSF 14/NSF 61認證合格



CD Series

雙油任球閥

CD100 SOCKET/ CD200 THREAD/ CD300 FLANGE
Size: 1/2"- 4"

● MATERIALS OF CONSTRUCTION

Item	Parts	Pcs	Materials	Item	Parts	Pcs	Materials
1	BODY	1	UPVC,PP,CPVC,PVDF	8	STEM O'RING	2	EPDM,VITON
2	BALL	1	UPVC,PP,CPVC,PVDF	9	END'S O'RING	1	EPDM,VITON
3	SEAT CARRIER	1	UPVC,PP,CPVC,PVDF	10	BODY O'RING	1	EPDM,VITON
4	STEM	1	UPVC,PP,CPVC,PVDF	11	SEAT	1	PTFE
5	END CONNECTOR	2	UPVC,PP,CPVC,PVDF	12	SOLID CARRIER O'RING	2	EPDM,VITON
6	UNION NUT	2	UPVC,PP,CPVC,PVDF	13	SOLID END O'RING	1	EPDM,VITON
7	HANDLE	1	ABS	14	FLANGE	2	UPVC,PP,CPVC,PVDF

● DIMENSIONS TABLE

Nom Size DN-Inch	D1	D2	D3	JIS										Unit:mm			
				d		øe	n	P	L			A	T	H	B	Testpress (kgf/cm ²)	Working press (kgf/cm ²)
				Socket	Thread				Socket	Thread	Flange						
15(1/2")	15	70	95	22	PT1/2	15	4	22.2	112	112	152	82.5	15	61	47	22.5	15
20(3/4")	20	75	100	26	PT3/4	15	4	25.4	130	130	170	101	15	64	61	22.5	15
25(1")	25	90	125	32	PT1	19	4	28.6	144	144	189	111	17	65	70	22.5	15
32(1-1/4")	38	100	135	38	PT1-1/4	19	4	31.8	167	167	211	111	17	89	93	22.5	15
40(1-1/2")	38	105	140	48	PT1-1/2	19	4	34.9	185	185	232	128.3	17	88.7	93	22.5	15
50(2")	48	120	155	60	PT2	19	4	38.1	198	198	250	152.5	20	108.5	113	22.5	15
65(2-1/2")	65	140	175	76	PT2-1/2	19	4	44.5	228	228	279	190	20	140	150	15	10
80(3")	78	150	185	89	PT3	19	8	47.6	273	273	328	230	23	165	184	15	10
100(4")	102	175	210	114	PT4	19	8	57.2	323	323	378	274	23	172	226	15	10

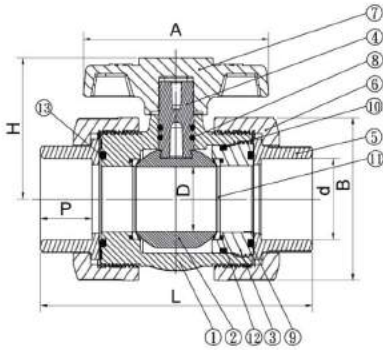

SOCKET & SCREW TYPE

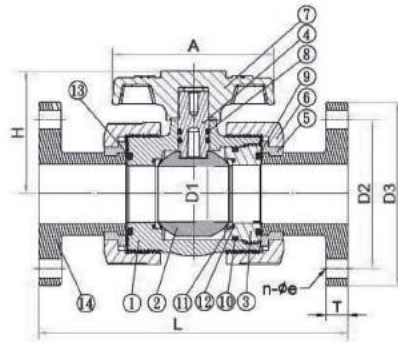

15A-50A FLANGE TYPE

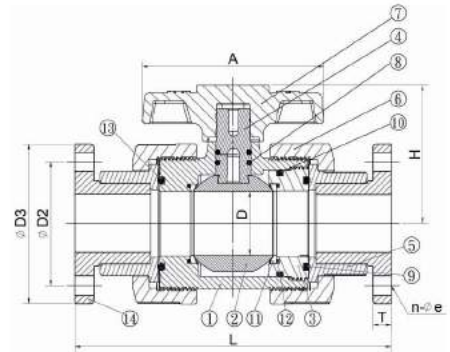

65A-100A FLANGE TYPE

DIMENSIONS TABLE

ANSI														Unit:inch			
Nom Size DN-inch	D1	D2	D3	d		øe	n	P	L			A	T	H	B	Test Press (lb/in ²)	Working press (lb/in ²)
				Socket	Thread				Socket	Thread	Flange						
15(1/2")	0.591	2.375	3.500	0.848	NPT1/2	0.625	4	0.875	4.409	4.409	5.984	3.248	0.590	2.402	1.850	353	235
20(3/4")	0.78	2.750	3.875	1.058	NPT3/4	0.625	4	1.000	5.118	5.118	6.693	3.976	0.590	2.52	2.402	353	235
25(1")	0.984	3.125	4.250	1.325	NPT1	0.625	4	1.125	5.669	5.669	7.441	4.331	0.669	2.559	2.755	353	235
32(1-1/4")	1.496	3.500	4.625	1.670	NPT1-1/4	0.625	4	1.250	6.574	6.574	8.307	4.370	0.669	3.504	3.661	353	235
40(1-1/2")	1.496	3.875	5.000	1.912	NPT1-1/2	0.625	4	1.375	7.283	7.283	9.134	5.051	0.700	3.799	3.661	353	235
50(2")	1.89	4.750	6.000	2.387	NPT2	0.750	4	1.500	7.795	7.795	9.843	6.003	0.820	4.272	4.449	353	235
65(2-1/2")	2.56	5.500	7.000	2.889	NPT2-1/2	0.750	4	1.750	8.976	8.976	10.984	7.480	0.787	5.512	5.905	225	150
80(3")	3.071	6.000	7.500	3.515	NPT3	0.750	4	1.875	10.748	10.748	12.913	9.055	0.905	6.496	7.244	225	150
100(4")	4.01	7.500	9.000	4.518	NPT4	0.750	8	2.250	12.716	12.716	14.882	10.787	0.905	6.772	8.897	225	150

DIN														Unit:mm			
Nom Size DN-inch	D1	D2	D3	d		øe	n	P	L			A	T	H	B	Test Press (bar)	Working press (bar)
				Socket	Thread				Socket	Thread	Flange						
15(1/2")	15	65	95	20	R1/2	14	4	16.0	112	112	152	82	15	61	47	24	16
20(3/4")	20	75	105	25	R3/4	14	4	18.5	130	130	170	101	15	65	61	24	16
25(1")	25	85	115	32	R1	14	4	22.0	144	144	189	110	17	70	70	24	16
32(1-1/4")	38	100	140	40	R1-1/4	18	4	26.0	167	167	211	126	17	83	93	24	16
40(1-1/2")	38	110	150	50	R1-1/2	18	4	31.0	185	185	232	126	17	88.7	93	24	16
50(2")	48	125	165	63	RT2	18	4	37.5	198	198	250	152	20	108.5	113	24	16
65(2-1/2")	65	145	185	75	R2-1/2	18	4	43.5	228	228	279	190	20	140	150	15	10
80(3")	78	160	200	90	R3	18	8	51.0	273	273	328	230	23	165	184	15	10
100(4")	102	180	220	110	R4	18	8	61.0	323	323	378	274	23	172	226	15	10

※ 本尺表以 PVC 材質為準，本表試壓值以 PVC、PVDF 材質為基準，PP 材質試壓值為本表試壓值之 70%。

※ 法蘭長度公差依據 EN558-1:1995 標準

The dimension table is calculably based on PVC material.
 ✖ The valve of test pressure is calculably based on PVC PVDF materials.
 The valve of test pressure for PP material is 70% based on the table.
 The flanged length tolerance is according to EN558-1:1995.